

Specifications

Output Power HP (kW)	60 (45)
Phase	3 Phase
Pole	4 Pole
Frame Number	200L

Degrees of Protection	IP 55
Enclosure Construction	Totally-enclosed Fan-cooled
Thermal Class	Class F (155 °C)

Alignment	Horizontal
Frame Material	Cast Iron

Power Transmission	Direct-couple or Belt Driven
Direction of Rotation	Counterclockwise (CCW) viewed from shaft-end side



Connection Type	Lead Wire (6 Leads)
Coating Colour	Munsell N5.5 (Gray)
Conformed Standard	IEC 60034-1 & JEC-2137-2000



Voltage & Frequency	HT Type
	380~415V 50Hz 380~440V 60Hz (suitable for Y-Δ starting)

* The perpendicular variation of tolerance for the shaft center is ± 0.5

Dimensions (mm)

Motor												
A	B	C*	D	E	F	G	H	J	JK	K	L	M
370.5	281	200	410	159	152.5	25	405	80	R6	78	796	390

Motor			Terminal Box				Shaft End						
N	XB	Z	KA	KG	KD	KP	Q	QK	R	S	T	U	W
369	133	18.5	120	476	PF 2	550	140	110	425.5	60 m6	11	7	18

Bearing No.		Approximated Weight (kg)	Approximated Packing Dimensions (LxWxH)	Gross Weight (kg)
Drive End	Opposite			
6313ZZ	6311ZZ	310	964 x 542 x 691	337

Connection & Connection Diagram

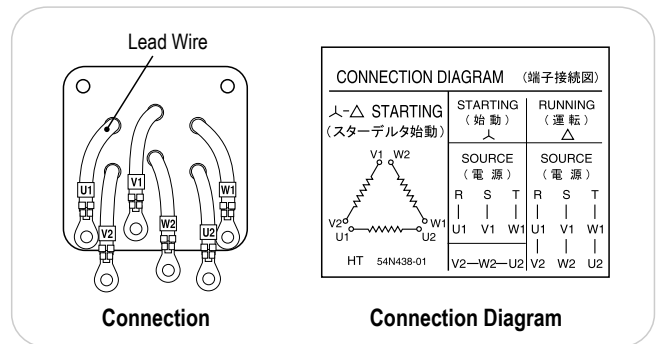

Circumstance Conditions

Ambient Temperature	-20 ~ +40°C
Ambient Humidity	95% RH or less
Operating Altitude	Less than 1,000m above sea level
Environment	No bursting / erosive gas or vapor

Motor Characteristics

Type	Hz	V	50% Load			75% Load			100% Load				Torque(%)		Is (A)	Inertia GD ² (kg-m ²)		
			(A)	Eff(%)	PF(%)	(A)	Eff(%)	PF(%)	(A)	Eff(%)	PF(%)	Speed (r/min)	Torque (kg-m)	Ts			Tm	
HT	50	380	46.0	0.92	0.80	63.4	0.93	0.87	82.4	0.93	0.89	1450	30.23	296	270	650	1.77	
		415	49.3	0.90	0.71	63.0	0.92	0.81	79.1	0.92	0.86	1460	30.02	353	322			710
	60	380	41.9	0.93	0.88	60.2	0.93	0.91	79.9	0.93	0.92	1750	25.05	253	235			572
		440	40.9	0.92	0.79	54.2	0.93	0.86	70.4	0.93	0.89	1770	24.76	339	315			662